

Installation Instructions

Translation of the Original Instructions



HighPower-MicroSpotMonitor with HighBrilliance-Measuring Objective

Contents

1	SAFETY INSTRUCTIONS	4
2	MOUNTING THE HIGHBRILLIANCE MEASURING OBJECTIVE	6
2.1	Mounting the Absorber.....	6
2.2	Mounting the Magnet Spring.....	8
2.2.1	Handling of the Magnet Spring Sliders	8
2.2.2	Mounting	8
2.2.1	Maintenance of the Magnet Spring.....	10
2.3	Mounting the Measuring Objective.....	11
2.3.1	Removing Transport Lock at the Laser Output.....	12
2.3.2	Removing Transport Lock at the Measuring Output.....	12
2.3.3	Removing Transport Locks at the Beam Entrance.....	12
2.3.4	Fastening the Objective	13
2.4	Demounting the Measuring Objective	15
2.5	Demounting the Magnet Spring	16
2.6	Demounting the absorber.....	16
2.7	Exchanging the Protective Window in front of the Power Output Aperture	17
2.8	Exchanging Mirror 1	18
2.9	Replacing the Cover at the Beam Entrance Aperture	19
3	CONNECTING THE COOLING CIRCUIT	20
4	CONNECTING THE COMPRESSED AIR	21
5	MOUNTING THE FIBER BRIDGE	22
6	SHUTDOWN AND STORAGE	24
7	TECHNICAL DATA OF THE HIGHBRILLIANCE MEASURING OBJECTIVE	25
8	APPENDIX	26
8.1	Installation Instructions Magnet Spring (original instructions of the manufacturer).....	26

1 Symbol Explanations

The following symbols and signal words indicate possible residual risks:



DANGER

Means that death or serious physical injuries **will** occur if necessary safety precautions are not taken.



WARNING

Means that death or serious physical injuries **may** occur if necessary safety precautions are not taken.



CAUTION

Means that minor physical injury **may** occur if necessary safety precautions are not taken.

NOTICE

Means that property damage **may** occur if necessary safety precautions are not taken.

The following symbols indicating requirements and possible dangers are used on the device:



General warning sign



Hand injuries warning



Magnetic field warning



No access for people with pacemakers or implanted defibrillators



Read and observe the operating instructions and safety guidelines before startup!

2 Safety Instructions

With the HighBrilliance Measuring Objective a magnet spring is installed, which countervails the weight of the measuring objective and therefore disburdens the mobile motors of the z-axis. Please mind the following safety instructions when it comes to the handling of magnet springs:



DANGER

Danger to life for people with a cardiac pacemaker

The magnet springs sliders mainly consist of neodymium magnets (NdFeB magnets). These are much stronger than “ordinary” magnets and can affect the correct functioning of a cardiac pacemaker.

- ▶ If you have a cardiac pacemaker, keep a minimum distance of 1 m to the magnet spring.



WARNING

Danger of injury due to the strong magnet attraction

The magnet spring sliders can exert considerable forces as soon as they are close enough to other sliders or iron. If they are not handled with the utmost care, this can lead to serious injuries (contusions, broken fingers, etc.).

Magnet springs can act like tensioned springs. The sliders spring back to their original resting position as soon as they are let loose, even if the machine is disconnected from the energy supply.

- ▶ The magnet spring must only be mounted or demounted by trained personnel. Handle the magnet spring with the utmost care when modifying the objective. Take respective protective measures when it comes to the handling of magnet springs in order to prevent injuries.

3 Mounting the HighBrilliance Measuring Objective

Before the change of the objective a referencing procedure has to be triggered.

1. Turn the device off and on again.
2. The referencing procedure is now carried out automatically. This takes approx. 30 seconds.
3. Turn the device off again.

You can now change the objective.

3.1 Mounting the Absorber

 Necessary tools: hexagon key AF 2.5 mm and 5 mm. .

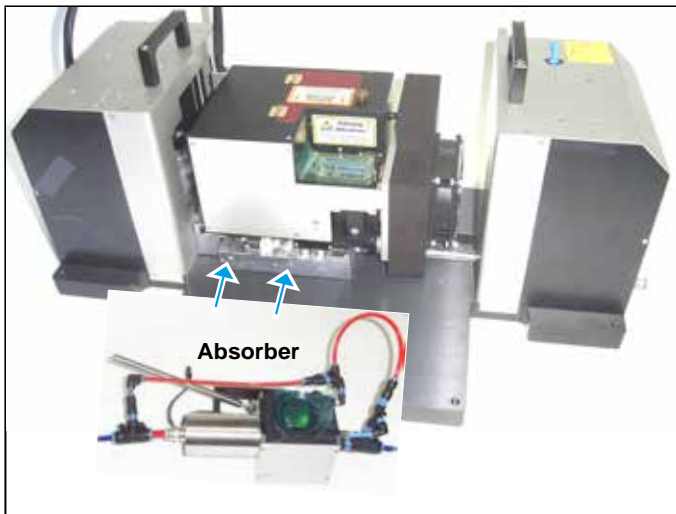

1. Move the HP-MSM to the lowest z-axis position.

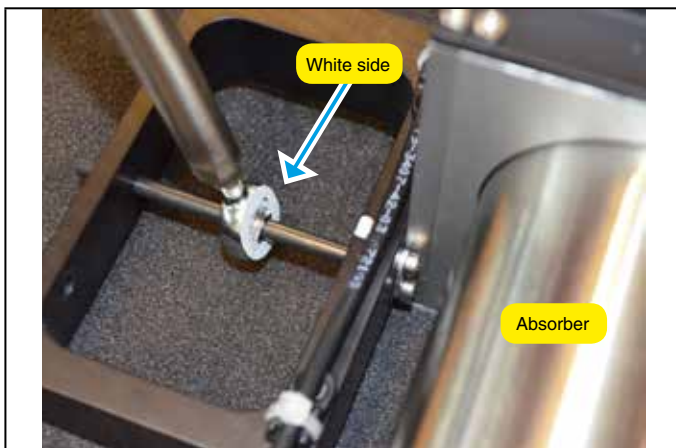

2. Mount the knuckle eye of the magnet spring.
Attention: The knuckle eye has a white side which has to face the absorber!

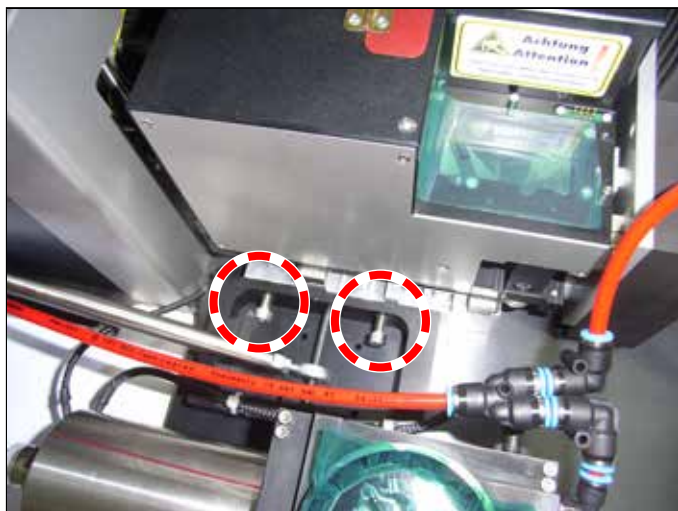

3. Fasten the absorber at the HP-MSM by means of 2 screws (M6, strength class 8.8, tightening torque 10.1 N·m).

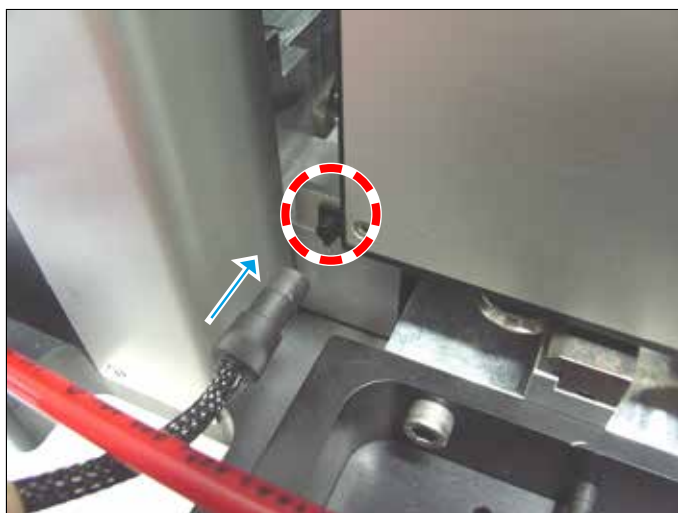

4. Insert the interlock plug into the respective device socket.

3.2 Mounting the Magnet Spring

3.2.1 Handling of the Magnet Spring Sliders

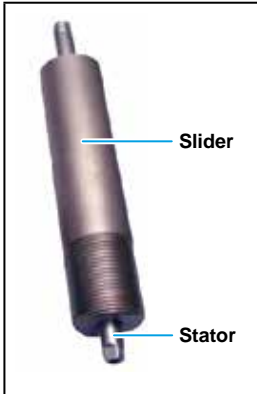

- The magnet spring sliders consist of a thin stainless steel tube in which the drive magnets can be found. The sliders are to be treated with caution. They may never collide with other sliders or iron parts, as this may damage the magnets as well as the rotator surface. Do not continue to use sliders with an already damaged surface (scratches, deformations, etc.), as this can lead to damages of the stator.
- Keep the slider away from open flames and heat (when it comes to temperatures over 80 °C, the slider is demagnetized).
- It is strictly prohibited to saw or drill the magnet spring sliders. This would break the magnets and, above all, the emerging drilling dust is easily inflammable!

NOTICE

Danger of damage due to a strong magnetic field.

Magnet spring sliders mainly consist of very strong magnets.

- ▶ **Keep a safety distance to all devices and parts which could be damaged by magnetism, e.g. TVs and screens, credit cards, computers, data mediums, video tapes, mechanical clocks, hearing aids and loud speakers.**

3.2.2 Mounting

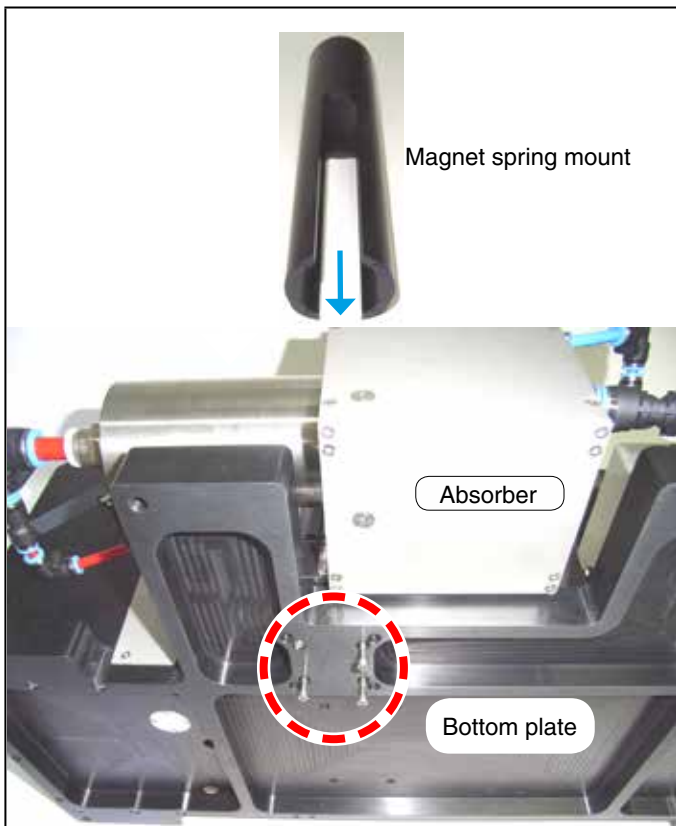

1. Turn the device by 90° to the side so that the bottom plate is in a vertical position.
2. Fasten the magnet spring mount to the bottom plate by using four screws.

Attention: The arrays on the bottom plate as well as the mounting have to point to each other!

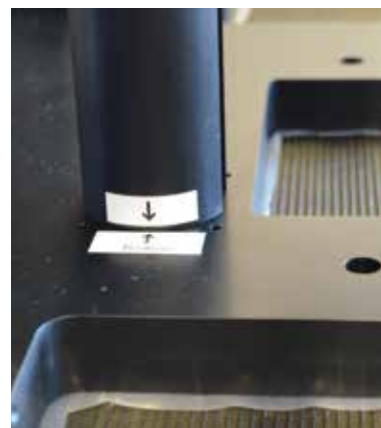

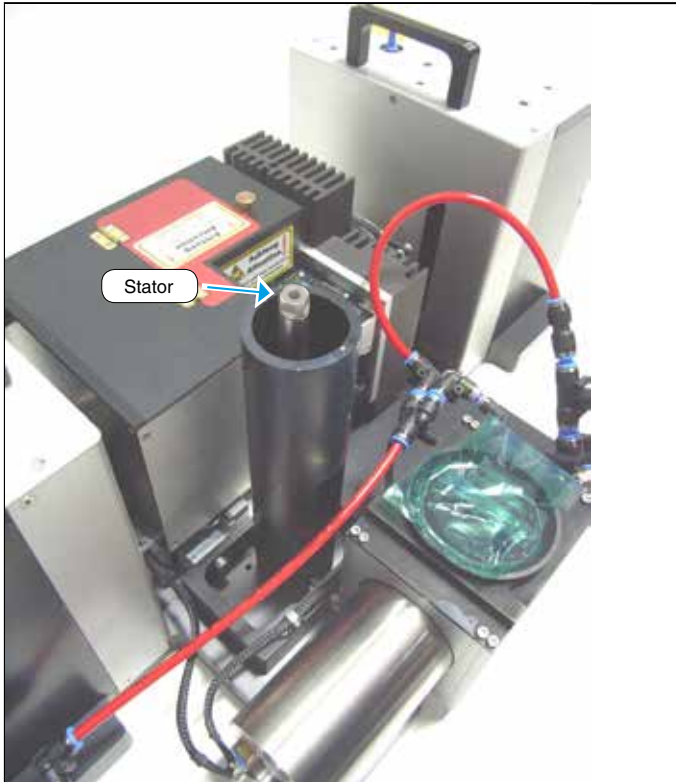

3. Replace the device in an upright position.
4. Move the HP-MSM to the lower position.

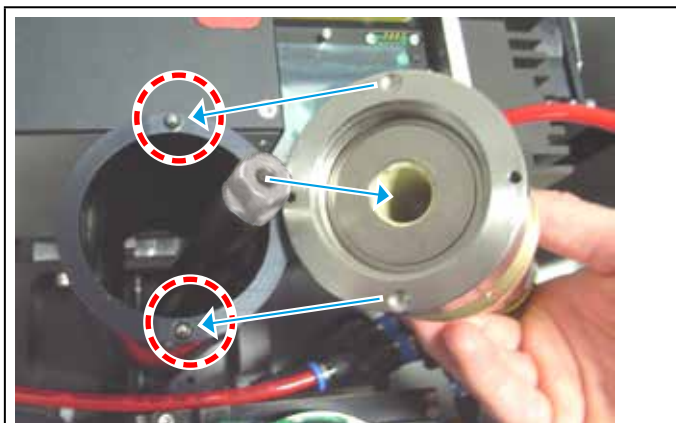

5. Position the slider centrally on the stator. The two deepenings (not the drills!) in the adjusting ring have to be positioned on the retaining tube.



Danger of crushing!

Caution when putting on the slider. It is abruptly and forcefull drawn.

Attention: The arrays on the slider as well as the mounting have to point to each other!



3.2.1 Maintenance of the Magnet Spring

We recommend a regular inspection of the magnet spring, approximately every 6 months. The following points have to be checked during the inspection:

- ▶ Is the slider completely covered with the lubricant?
- ▶ Is the lubricant free of pollution?
- ▶ Can the slider be moved without much effort?

Cleaning

Hard brushes or similar tools must not be used for cleaning. Cleaning fluids which contain solvent additives, petroleum or comparable products must not be used. When cleaning it, please proceed as follows: Clean the slider and stator with a paper towel. Residues can be removed methylated spirits or alcohol. Apply lubricant on the slider and insert it carefully.

Lubrication

For the lubrication we recommend KLÜBERSYNTH UH1 14-31.

3.3 Mounting the Measuring Objective



CAUTION

Danger of damage of optical components

The beam entrance aperture, the power output aperture and the measuring output aperture are covered with transport locks.

- ▶ The transport locks at the measuring objective are not be removed until the mounting or directly before the startup.
The transport locks as well as the corresponding o-ring are to be kept in a clean, sealable plastic bag.
After each demounting of the measuring objective, the apertures are to be closed with the corresponding transport locks again!

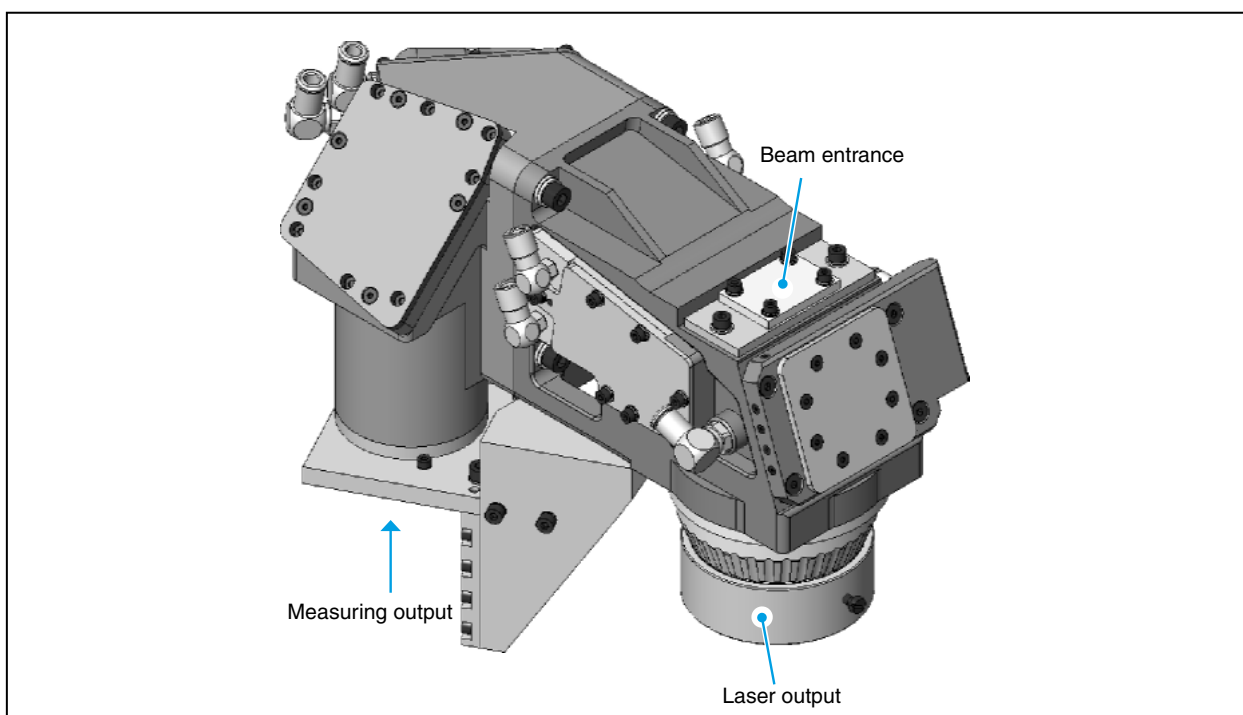

Fig. 3.1: Transport locks of the measuring objective



Required tools:

Hexagon socket screw key, AF 2.5 mm
Slotted screwdriver, size 6.5

3.3.1 Removing Transport Lock at the Laser Output

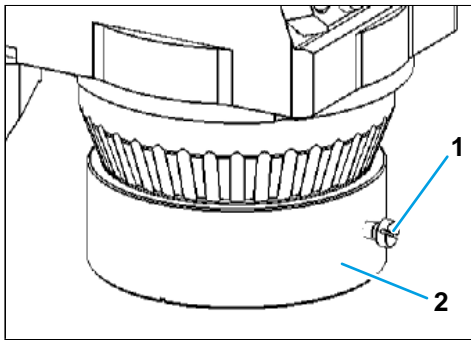

- ▶ Unscrew slotted screw M4 x 40 (1).
- ▶ Remove transport lock (2).

The transport lock is mounted in reverse order.

3.3.2 Removing Transport Lock at the Measuring Output

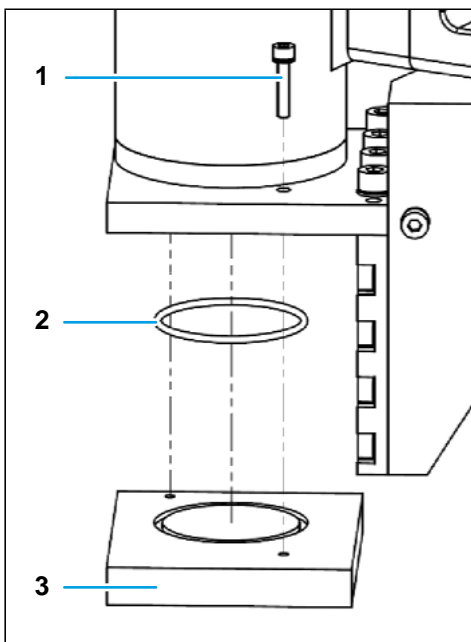

- ▶ Unscrew two cylinder head screws M3x16 (1).
- ▶ Remove transport lock (3). Please mind that the o-ring (2) remains in the transport lock and does not stick to the objective.

The transport lock is mounted in reverse order.

3.3.3 Removing Transport Locks at the Beam Entrance

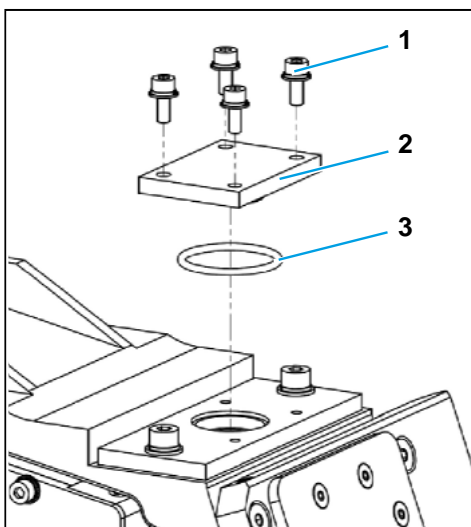

- ▶ Unscrew four cylinder head screws M3x8 (1) with washer and spring lock washer.
- ▶ Remove transport lock (2). Please mind that the o-ring (3) remains in the transport lock and does not stick to the objective.

The transport lock is mounted in reverse order.

3.3.4 Fastening the Objective

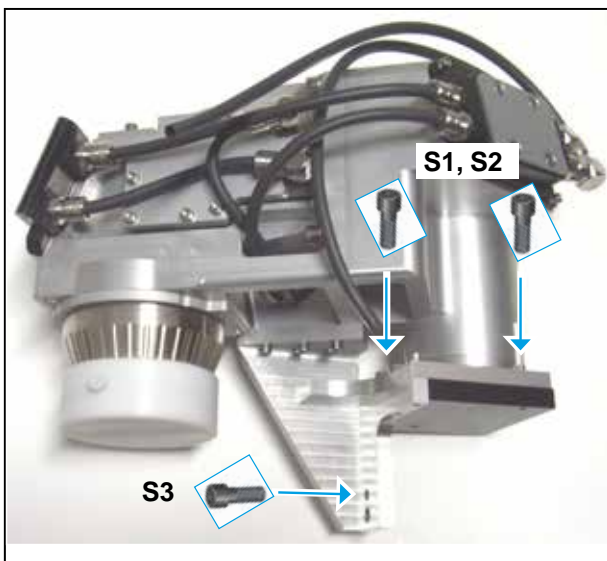

- ▶ The objective is fastened at the device by means of three screws. The two screws of the transport lock S1 and S2 (M3x16, AF 2.5 mm) are required for the fastening of the objective on the device surface.
- ▶ Another screw S3 (M5 x 15, AF 4 mm) fastens the upright of the device laterally.

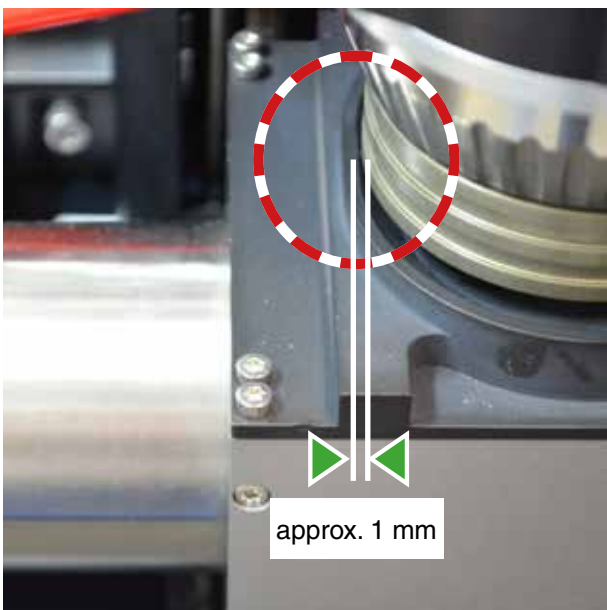

- ▶ The objective has to be mounted in a way which leaves an air gap of approx. 1 mm on both sides of the absorber.

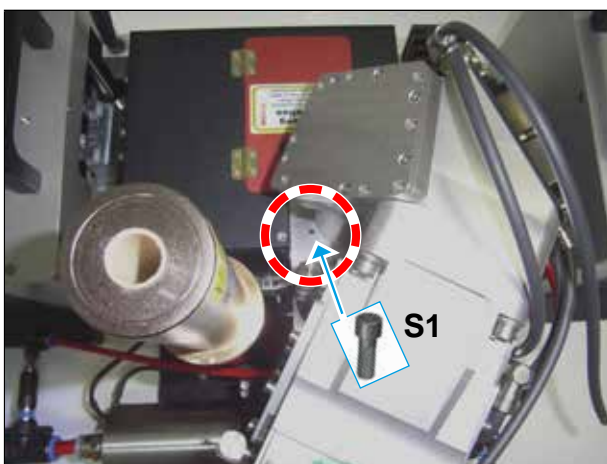

- ▶ Put the measuring objective on the device and fasten it with the screws S1 and S2 (M3, strength class 8.8, tightening torque 1.3 N·m).

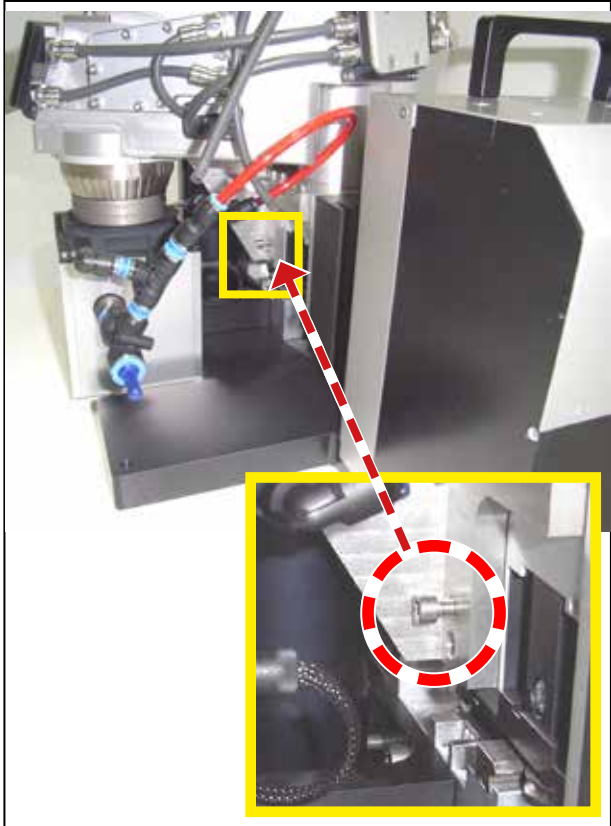
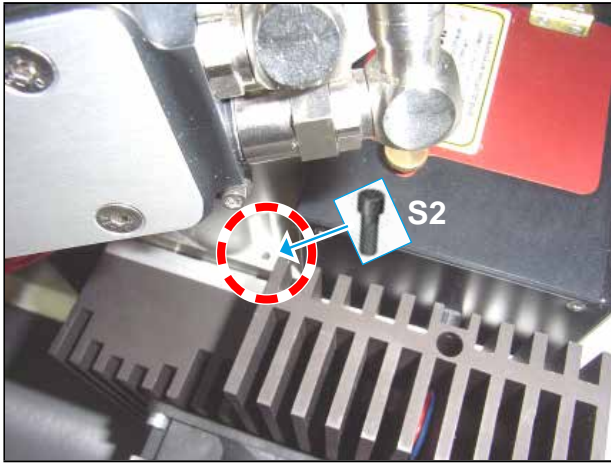

- ▶ Fasten the upright of the objective with screw S3 (M5 x 25, strength class 8.8, tightening torque 5.9 N·m).

3.4 Demounting the Measuring Objective

- ▶ Turn off the voltage supply.
- ▶ Turn off the cooling water and the compressed air supply.
- ▶ Mount the transport lock at the beam entrance aperture.
- ▶ Disconnect the cooling water pipes at the quick connect couplings.
- ▶ Remove compressed air hose from the connection for the housing flushing.
- ▶ Remove the fastening screws(see chapter 3.3.4 on page 13).
- ▶ Remove measuring objective
- ▶ Mount all further transport locks (see chapter 3.3.1, 3.3.2 and 3.3.3 on page 12).
- ▶ Drain cooling water and blow the cooling water pipes out with compressed air.
- ▶ Dry and clean the measuring objective.

3.5 Demounting the Magnet Spring

Demount the magnet spring in reverse order to the description in chapter 3.2.2 on page 8.

Please mind the following:

In order to protect the stator of the magnet spring, a protection cover is enclosed. As soon as the slider of the magnet spring is removed, the protection cover is positioned between the magnet spring and the stator (picture A) and is then fixed by means of a screw (picture B).

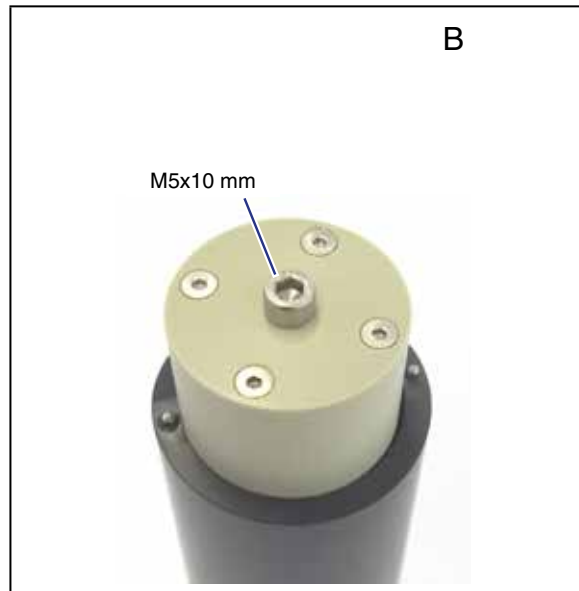
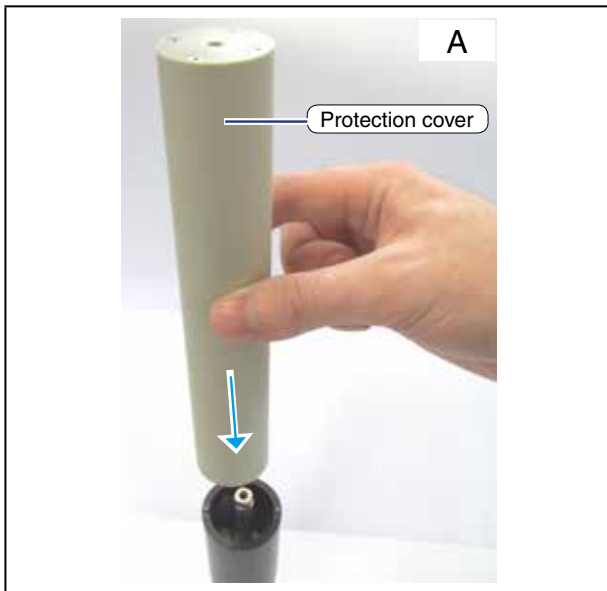

If you want to push the stator into the slider after the demounting, please mind the following:



WARNING

Danger of injuries due to a strong magnetic attraction

The stator is dragged into the slider with great strength and shoots out of the slider on both sides.

- ▶ Please wear gloves and only touch the coverage as shown on the above picture when holding the stator and the slider. Do not hold your palm in front of the front side of the slider when pushing in the stator!

3.6 Demounting the absorber

Demount the absorber in reverse order to the description in chapter 3.1 on page 6.

3.7 Exchanging the Protective Window in front of the Power Output Aperture

 Necessary Tools: Screw-in tools for the retaining ring is included in the scope of delivery



CAUTION

Danger of damage for the optical components

A contaminated protective window can heat up and thereby destroyed.

- ▶ **Keep the protective window free from contaminations. Do not touch the plane surface of the protective window when putting it in!**

The protective window protects the optical elements behind it from contaminations. A polluted protective window does not affect the function of the measuring objective. However, the increased scattering of the laser light leads to a heating up of the protective window and the housing which can finally result in the destruction of the protective window itself. This can damage sensitive optical components in the measuring objective. Therefore, a contaminated protective window has to be exchanged immediately.

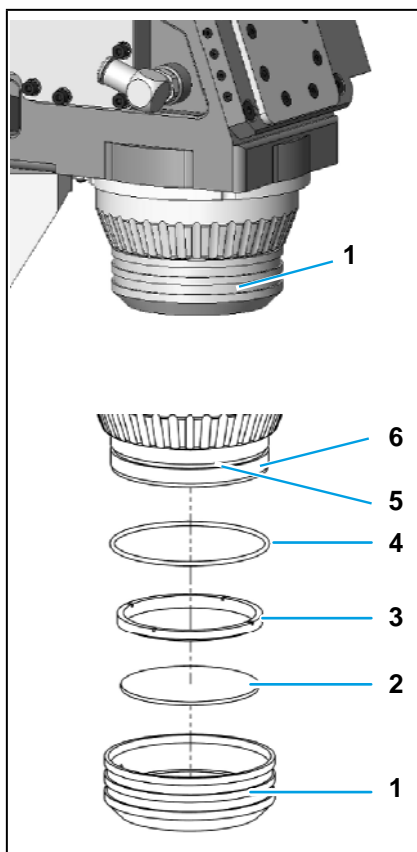

Components:

- 1 Protective Window Retainer
- 2 Protective Window
- 3 Ring Nut
- 4 O-Ring 60.08 x 1.78
- 5 Nut for O-Ring (4)
- 6 Optics Tube

- ▶ Carefully remove the protective window retainer (1).
- ▶ Check o-ring (4) in the nut (5) for damages and a tight fit. If necessary, it has to be replaced.
- ▶ Remove the ring nut (3) from the protective window retainer by means of the screw-in tools.
- ▶ Take the protective window (2) out of the protective window retainer and replace it by a new protective window.
- ▶ Screw the ring nut back in the protective window retainer.
- ▶ Position the protective window retainer back on the optics tube.

3.8 Exchanging Mirror 1

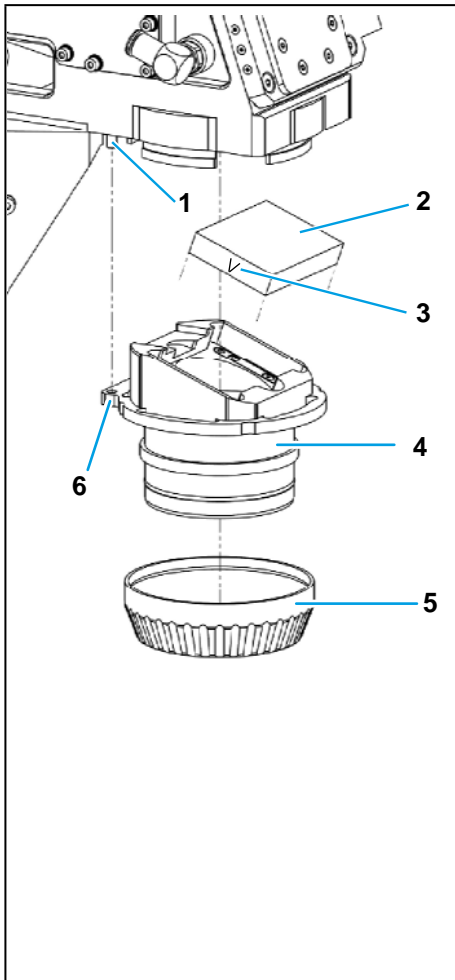

Components:

- 1 Cylinder pin ISO 2338 m6 4x12
- 2 Mirror
- 3 Labeling "Arrow" has to point downwards.
- 4 Optics tube
- 5 Coupling Ring
- 6 Drilling

- ▶ Remove protective window retainer, see previous chapter.
- ▶ Remove coupling ring (5).
- ▶ Pull optics tube (4) out of the housing.
- ▶ Remove the mirror (2).
- ▶ Clean the mirror thoroughly. A new mirror has to be cleaned before it can be built in as well.
- ▶ Turn the mirror until the arrow (3) on the side of the mirror points downwards (see fig.).
- ▶ Put in the mirror carefully.
- ▶ Push the optics tube back into the housing. The pin (1) has to be pushed into the drilling (6).
- ▶ Screw the coupling ring on manually.
- ▶ Check the protective window in the protective window retainer for contaminations. If necessary, it has to be replaced (please see the previous chapter).
- ▶ Mount the protective window retainer.

3.9 Replacing the Cover at the Beam Entrance Aperture

 Necessary tools: Hexagon socket screw key, AF 3 mm

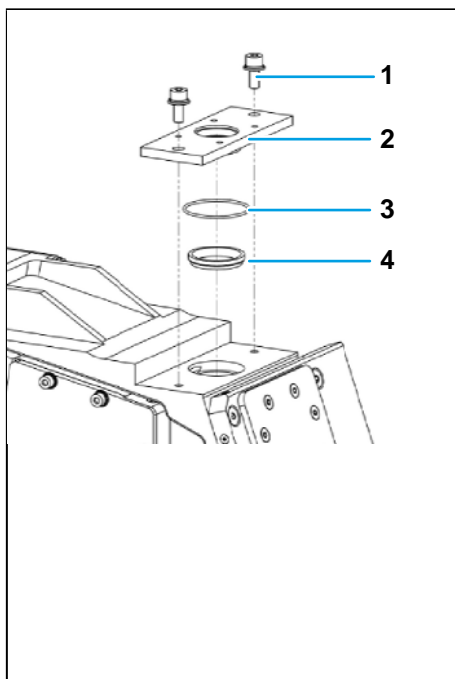

Components:

- 1 Cylinder Screw ISO 4762 M4x10
- 2 Cover
- 3 O-Ring 21.95 x 1.78
- 4 Centering ring (option)

- ▶ Unscrew two cylinder screws (1) with spring washer and grommet.
- ▶ Remove cover (2).
- ▶ Check o-ring (3) for damages and replace it if necessary.

Important!

The through-holes in the cover have clearance in order to be able to center the cover. As a positioning aid a centering (4) ring can be used.

- ▶ Put on the new cover with the o-ring and center it.
- ▶ Fasten the new cover with two cylinder screws (1).

4 Connecting the Cooling Circuit

The connections of the HP-MSM are intended for PE-hoses with a diameter of 12 mm. For a reliable operation, a water flow rate of 7 l/min up to 8 l/min is required. In case of an unpressurized outflow, 2 bar primary pressure at the input of the absorber are normally enough.



Do not add any additives to the cooling water, especially no anti-freeze agents. These can change the thermal conductivity significantly which then reduces the cooling capacity.

Only operate the HP-MSM in a non-condensing atmosphere. The temperature of the cooling water must not be lower than the ambient temperature.

Only cool the water during the measuring operation. We recommend starting the cooling process approx. 2 minutes before a measurement and to terminate it approx. 1 minute after the measurement.



5 Connecting the Compressed Air

Connect the compressed air supply via a PE-hose with an outer diameter of 6 mm. A pressure of 3 bar ... 4 bar is required.



In the HP-MSM, compressed air is cleaned by means of three filters and the pressure is controlled via an air regulator. The air regulator is preset for a pressure of 3 bar ... 4 bar. If this value is exceeded, the compressed air supply is interrupted.

6 Mounting the Fiber Bridge

⚠ CAUTION

Danger of damage of the fiber optic holder in case of a mounted fiber bridge.

In the upper z-axis position the cyclone can collide with the fiber optic holder and damage it.

- ▶ Dismount the cyclone before the startup!

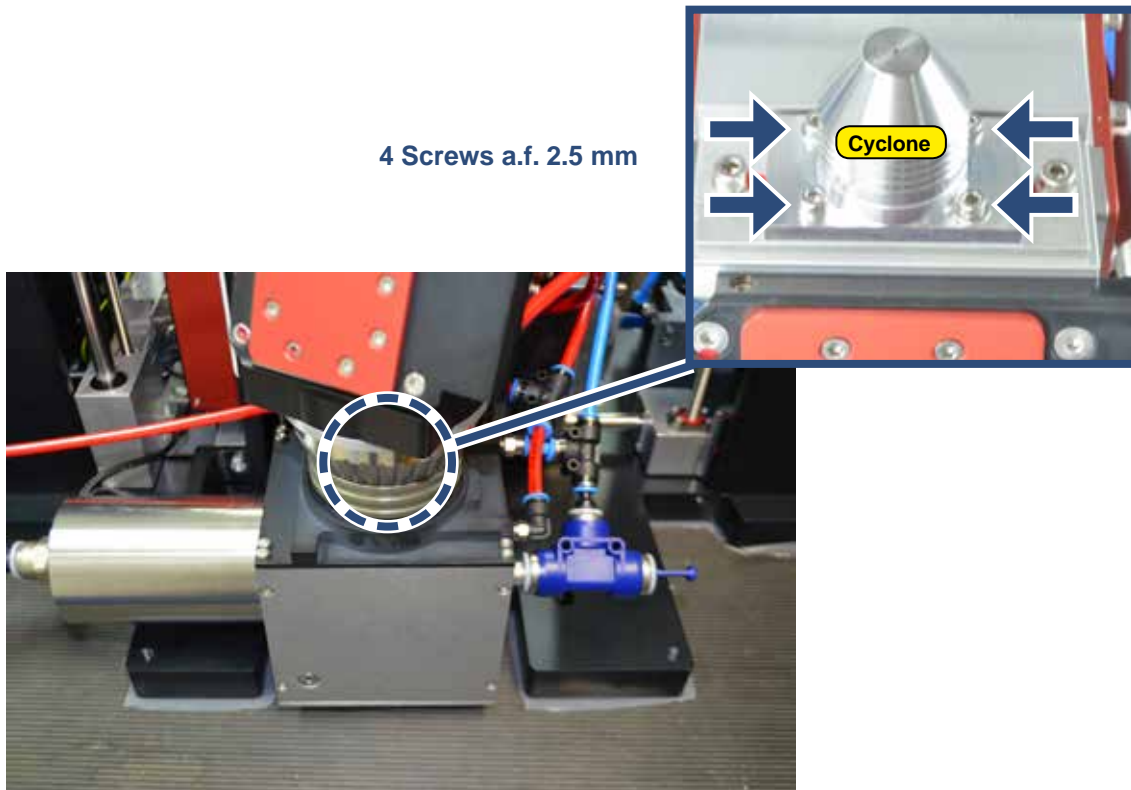

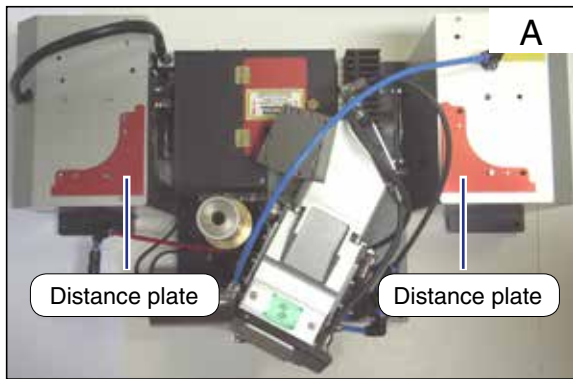

1. Put the distance plates on both sides of the housing (picture A) and fasten them by means of the dowel pins.

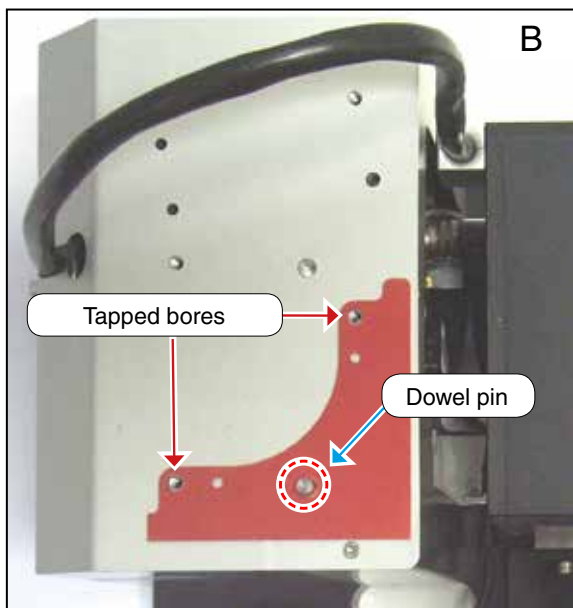

2. Align the plates with reference to the tapped bores (picture B).

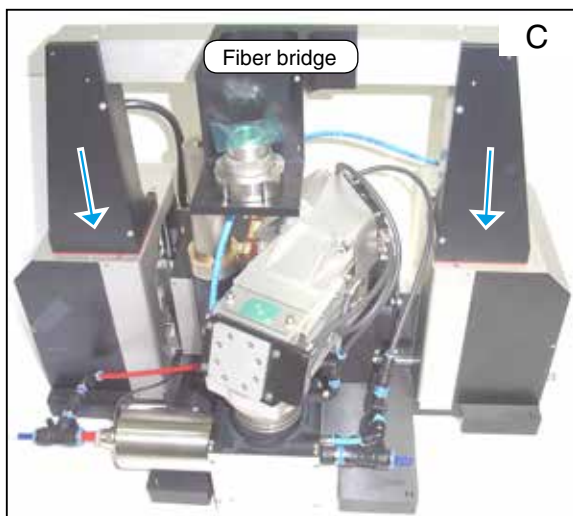

3. Put the fiber bridge on the distance plates.

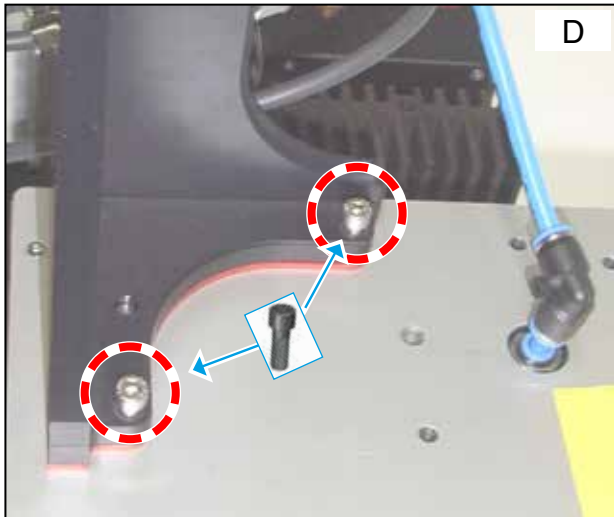

4. Fasten the fiber bridge by means of two screws on both sides M5 x 10 mm.

7 Shutdown and storage

NOTICE

Danger of damage

A storage or transport with temperatures near or below the freezing point and a cooling circuit which is not completely empty can lead to device damages.

- ▶ **Empty the pipe system of the cooling circuit completely.**

For the transport or a longer storage, please drain the cooling water and clean the pipes with compressed air.

Put the measuring objective into a clean, sealable plastic bag. Add a drying agent to ensure that the lenses do not come in contact with condensed water.

8 Technical Data of the HighBrilliance Measuring Objective

Admissible laser power	kW	8
Admissible wavelength range of the laser light	nm	1025 - 1080
Admissible measuring range	-	$\pm 3z_R$
Beam diameter in the measuring plane	μm	20 ... 1000
Design wavelength	nm	1064
Magnification	-	4.5
Max. input-NA	-	0.11
Free working distance, approx.	mm	37.8
Weight, approx.	kg	5.5

9 Appendix

9.1 Installation Instructions Magnet Spring (original instructions of the manufacturer)



Assembly Instructions *MagSpring®*

Version 1.3

CAUTION

MAGSPRING SLIDERS CONTAIN NEODYMIUM MAGNETS WHICH MAY DISTURB OR DAMAGE MAGNETIC DATA CARRIERS AND DELICATE ELECTRONIC EQUIPMENT LIKE PACEMAKERS, CELLPHONES, COMPUTERS OR WATCHES MERELY BY COMING CLOSE TO THEM.



DO NOT HEAT THE SLIDERS. THE MAGNETS WILL BE DESTROYED BY TEMPERATURE HIGHER THAN 80°C (180°F)



WHEN HANDLING SLIDERS BE AWARE THAT, DUE TO THE STRONG MAGNETIC ATTRACTION, INJURY FROM FINGERS BEING PINCHED BETWEEN THE SLIDER AND NEARBY STEEL PARTS IS A VERY REAL POSSIBILITY IF CAUTION IS NOT EXERCISED.



MAGSPRING SLIDERS 'SNAP' TO THEIR CENTER POSITION WHEN RELEASED, OR UPON POWER SHUTDOWN OF THE MACHINE THEY ARE INSTALLED ON. ACCORDINGLY, CARE MUST BE TAKEN TO GUARD AGAINST INJURY TO PEOPLE IN THE AREA WHERE THE MAGSPRINGS ARE BEING USED.



AVOID HITTING SLIDERS AGAINST STEEL PARTS, TOOLS, ETC., AS THIS MAY PERMANENTLY DAMAGE THE SLIDER (SURFACE DAMAGE OR BENDING.) DO NOT SAW, TURN, DRILL OR CUT OFF THE SLIDERS BECAUSE THIS WILL DESTROY THE SLIDERS AND MAY LEAD TO INFLAMMABLE DUST.



Assembling *MagSpring*[®]



Introduction

Typical applications for the *MagSpring*[®] include:

- Counter balancing payload so that small Linear Motors can be used, particularly in vertical applications
- Retracting motor and load in the event of a power loss or E-stop condition
- Assisting Linear Motor in applications that require high force in one direction and lower force in the other by using motor to load spring while moving (returning) in low force requirement direction.



The mounting position of the *MagSpring*[®], with respect to the H-Guide, determines the direction of the movement in which the *MagSpring*[®] is providing assistance. The exact placement of the *MagSpring*[®] on the H-Guide is defined by the stroke range of the combined *MagSpring*[®] / H-Guide / MPC assembly.

Mounting

Placing the slider into the stator

1. The force class of the slider is written on one end of the slider (e.g. the description 'M102033-20' means serial no M102033 / force class 20). Normally the slider end with the description is opposite the payload
2. Clean the slider with disposable paper.
3. Lubricate the slider as noted in 'Maintenance of *MagSpring*[®]' section).
4. Enter the slider as in photo exactly longitudinally to the stator (attention: slider will be sucked into the stator and may shoot out on the opposite end of the stator).
5. The SP distance (Start Position see data sheet) is calculated from the 'slider end without description' to the front end of the stator (stator end with thread).



Attaching the load

The load must be mounted only to the end of the slider facing the load mass using a suitable open-end wrench (beware there will be magnetic attraction between wrench and slider). Under no circumstances may the slider tube or the back end of the slider be used as "clamping piece".

Assembling MagSpring®



Mounting MagSpring® Stators

MagSpring® Stators can be mounted either by using the thread on the barrel of the Stator or by using a MF01-xx mounting flange. When using the mounting flange be aware that over tightening may damage the stator.

Hint for proper mounting of Payload (adjustment of an angle offset)

Fixed End Washer Set PLF01-12 (Part-No 0150-3085) consisting of two pair of ball and socket washers, allows adjustment of an angle offset. The adjustment in the x- and y- direction is done by using an oversized hole for the mounting plate screw.

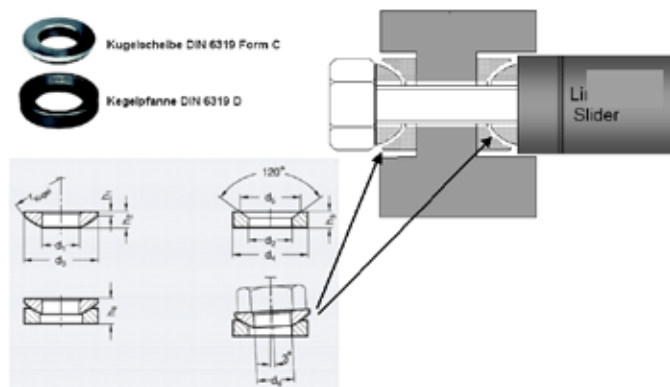

Function: Ball and socket washers adjust for angular offset between linear motor slider and Payload. (A spring washer should be used as well.)

Screw	d ₁	d ₂	d ₃	d ₄	d ₅	h ₁	h ₂	h ₃	h ₄	
M5	5,2 mm (0.20 in)	6,0 mm (0.24 in)	10,5 mm (0.41 in)	10,5 mm (0.41 in)	9,5 mm (0.37 in)	0,5 mm (0.02 in)	2,0 mm (0.08 in)	2,1 mm (0.08 in)	3,2 mm (0.13 in)	

Material: Hardened steel

Mounting of Payload with play-bushing

Play-bushing to handle alignment

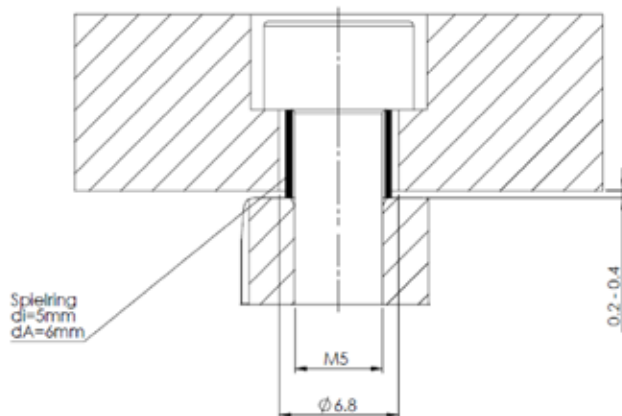

Assembling *MagSpring*[®]



Maintenance of *MagSpring*[®]

The maintenance schedule below is based on a 5-day week with 8 working hours daily. Normal plant industrial operating conditions are assumed. Where conditions differ, such as with severe and/or dirty environments, direct sunshine, operation outside etc., the maintenance intervals must be shortened until empirical values for the particular application are obtained. Accordingly a distinction is drawn between the maintenance schedules for standard applications and first time applications or arduous conditions.

Maintenance schedule for standard applications

	Less than 120 strokes/min	120 to 360 strokes/min	Over 360 strokes/min
Commissioning	Inspection and lubrication	Inspection and lubrication	Inspection and lubrication
Every 3 months	--	Inspection	Inspection and lubrication
Every 6 months	Inspection	Inspection and lubrication	Inspection and lubrication

Maintenance schedule for first applications / arduous environment

	Less than 120 strokes/min	120 to 360 strokes/min	Over 360 strokes/min
Commissioning	Inspection and lubrication	Inspection and lubrication	Inspection and lubrication
After the first 8 hours	Inspection	Inspection	Inspection
After the first week' operation	Inspection	Inspection	Inspection
Every 3 months	Inspection	Inspection	Inspection and lubrication
Every 6 months	Inspection and lubrication	Inspection and lubrication	Inspection and lubrication

Inspection

The following must be checked when inspecting the drives: 1.) Slider is lubricated completely 2.) Lubricant is not dried out 3.) Slider moves freely?

Cleaning

Do not use stiff brushes for cleaning. No cleaning fluids containing solvents, kerosene or similar are to be used: Carefully withdraw the slider from the stator. Clean the slider and stator with soft disposable paper, assisted by methylated spirit or alcohol possibly. Lubricate the slider and replace it carefully

Lubricating instructions

The lubricant reduces the friction between the chromium-nickel steel surface of the slider and the plastic sleeve bearing (POM or Delrin-based). In addition it prevents (fretting) corrosion. Important also is that it should retain low viscosity at low temperatures, and still not evaporate over time.

We recommend that the following lubricant be used (this Lubricant corresponds to KLÜBERSYNTH UH1 14-31 which was developed especially for the food processing industry):

Art. No.	0150-1953	(8g)
Art. No.	0150-1954	(50g)
Art. No.	0150-1955	(1000g)

Storage / transportation

- Sliders are to be stored and transported only in the provided shipping containers unless placed in *MagSpring*[®] stators.
- Maximum storage temperature: -40° ...+60 °C

Assembling MagSpring®



Mechanical dimensions of the stators MS01-20

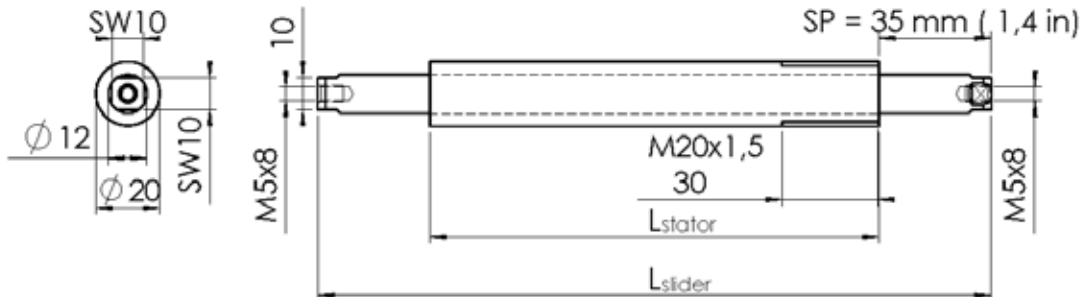

Stator	Part-Nr	Länge L _{Stator}	Durchmesser	Masse
MS01-20x60	0250-2200	60 mm [+/-0.1] (2.36 in)	20 mm (0.787 in)	75 g (0.16 lb)
MS01-20x140	0250-2201	140 mm [+/-0.1] (5.51 in)	20 mm (0.787 in)	180 g (0.37 lb)
MS01-20x220	0250-2202	220 mm [+/-0.15] (8.66 in)	20 mm (0.787 in)	285 g (0.58 lb)
MS01-20x300	0250-2207	300 mm [+/-0.15] (11.81 in)	20 mm (0.787 in)	389 g (0.8 lb)

Materials: Stator casing: Steel with Ni plating
bearing: based on POM (Delrin®)

Mechanical dimensions of the stators MS01-37

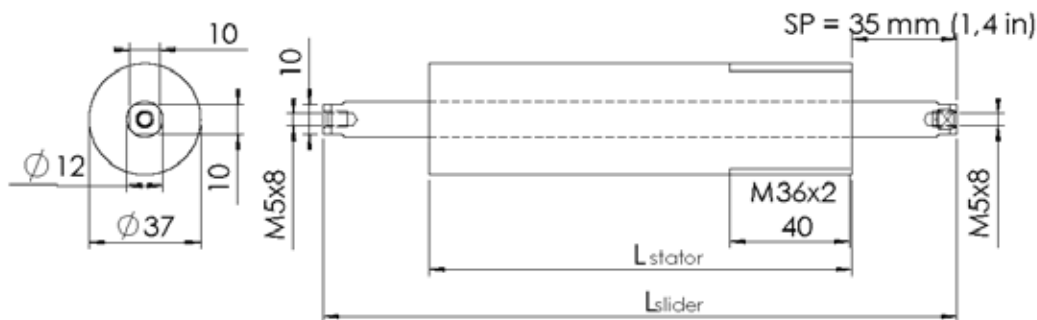

Stator	Part-Nr	Länge L _{Stator}	Durchmesser	Masse
MS01-37x80	0250-2203	80 mm [+/-0.2] (3.15 in)	37 mm (1.46 in)	440g (0.90 lb)
MS01-37x155	0250-2204	155 mm [+/-0.2] (6.10 in)	37 mm (1.46 in)	880 g (1.8 lb)
MS01-37x230	0250-2205	230 mm [+/-0.2] (9.05 in)	37 mm (1.46 in)	1320 g (2.7 lb)
MS01-37x305	0250-2206	305 mm [+/-0.2] (12.0 in)	37 mm (1.46 in)	1750 g (3.6 lb)

Materials: Stator casing: Steel with Ni plating
bearing: based on POM (Delrin®)

The stators can be mounted by the thread or by clamping.

Assembling *MagSpring*[®]



Slider	Part-Nr	Length L _{Slider}	Diameter	Mass	Thread
ML01-12x130/80-10	0250-2300	130 mm (5.12 in)	12 mm (0.47 in)	ca 75 g (0.16 lb)	M5
ML01-12x130/80-15	0250-2308	130 mm (5.12 in)	12 mm (0.47 in)	ca 75 g (0.16 lb)	M5
ML01-12x130/80-20	0250-2301	130 mm (5.12 in)	12 mm (0.47 in)	ca 75 g (0.16 lb)	M5
ML01-12x210/160-10	0250-2302	210 mm (8.27 in)	12 mm (0.47 in)	ca 155 g (0.30 lb)	M5
ML01-12x210/160-15	0250-2309	210 mm (8.27 in)	12 mm (0.47 in)	ca 155 g (0.30 lb)	M5
ML01-12x210/160-20	0250-2303	210 mm (8.27 in)	12 mm (0.47 in)	ca 155 g (0.30 lb)	M5
ML01-12x290/240-10	0250-2304	290 mm (11.42 in)	12 mm (0.47 in)	ca 220 g (0.45 lb)	M5
ML01-12x290/240-15	0250-2310	290 mm (11.42 in)	12 mm (0.47 in)	ca 220 g (0.45 lb)	M5
ML01-12x290/240-20	0250-2305	290 mm (11.42 in)	12 mm (0.47 in)	ca 220 g (0.45 lb)	M5
ML01-12x370/240-10	0250-2311	370 mm (14.56 in)	12 mm (0.47 in)	ca 280 g (0.57 lb)	M5
ML01-12x370/240-15	0250-2312	370 mm (14.56 in)	12 mm (0.47 in)	ca 280 g (0.57 lb)	M5
ML01-12x370/240-20	0250-2313	370 mm (14.56 in)	12 mm (0.47 in)	ca 280 g (0.57 lb)	M5

Materials: stainless steel 1.4301

Ordering information

Force	Stroke	MagSpring [®]	Stator		Slider	
			Description	Part-Nr	Description	Part-Nr
11 N	50 mm (1.97 in)	M01-20x60/50x11N	MS01-20x60	0250-2200	ML01-12x130/80-10	0250-2300
11 N	130 mm (5.1 in)	M01-20x140/130x11N	MS01-20x140	0250-2201	ML01-12x210/160-10	0250-2302
11 N	210 mm (8.3 in)	M01-20x220/210x11N	MS01-20x220	0250-2202	ML01-12x290/240-10	0250-2304
11 N	300 mm (11.8 in)	M01-20x300/290x11N	MS01-20x300	0250-2207	ML01-12x370/240-10	0250-2311
17 N	50 mm (1.97 in)	M01-20x60/50x17N	MS01-20x60	0250-2200	ML01-12x130/80-15	0250-2308
17 N	130 mm (5.1 in)	M01-20x140/130x17N	MS01-20x140	0250-2201	ML01-12x210/160-15	0250-2309
17 N	210 mm (8.3 in)	M01-20x220/210x17N	MS01-20x220	0250-2202	ML01-12x290/240-15	0250-2310
17 N	300 mm (11.8 in)	M01-20x300/290x17N	MS01-20x300	0250-2207	ML01-12x370/240-15	0250-2312
22 N	50 mm (1.97 in)	M01-20x60/50x22N	MS01-20x60	0250-2200	ML01-12x130/80-20	0250-2301
22 N	130 mm (5.1 in)	M01-20x140/130x22N	MS01-20x140	0250-2201	ML01-12x210/160-20	0250-2303
22 N	210 mm (8.3 in)	M01-20x220/210x22N	MS01-20x220	0250-2202	ML01-12x290/240-20	0250-2305
22 N	300 mm (11.8 in)	M01-20x300/290x22N	MS01-20x300	0250-2207	ML01-12x370/240-20	0250-2313
40 N	50 mm (1.97 in)	M01-37x80/50x40N	MS01-37x80	0250-2203	ML01-12x130/80-10	0250-2300
40 N	125 mm (4.92 in)	M01-37x155/125x40N	MS01-37x155	0250-2204	ML01-12x210/160-10	0250-2302
40 N	200 mm (7.87 in)	M01-37x230/200x40N	MS01-37x230	0250-2205	ML01-12x290/240-10	0250-2304
40 N	370 mm (14.6 in)	M01-37x305/275x40N	MS01-37x305	0250-2206	ML01-12x370/240-10	0250-2311
50 N	50 mm (1.97 in)	M01-37x80/50x50N	MS01-37x80	0250-2203	ML01-12x130/80-15	0250-2308
50 N	125 mm (4.92 in)	M01-37x155/125x50N	MS01-37x155	0250-2204	ML01-12x210/160-15	0250-2309
50 N	200 mm (7.87 in)	M01-37x230/200x50N	MS01-37x230	0250-2205	ML01-12x290/240-15	0250-2310
50 N	370 mm (14.6 in)	M01-37x305/275x50N	MS01-37x305	0250-2206	ML01-12x370/240-15	0250-2312
60 N	50 mm (1.97 in)	M01-37x80/50x60N	MS01-37x80	0250-2203	ML01-12x130/80-20	0250-2301
60 N	125 mm (4.92 in)	M01-37x155/125x60N	MS01-37x155	0250-2204	ML01-12x210/160-20	0250-2303
60 N	200 mm (7.87 in)	M01-37x230/200x60N	MS01-37x230	0250-2205	ML01-12x290/240-20	0250-2305
60 N	370 mm (14.6 in)	M01-37x305/275x60N	MS01-37x305	0250-2206	ML01-12x370/240-20	0250-2313

* nominal force +/- 15% at 20°C 1 N = 0.2248 lb

Assembling *MagSpring*[®]



Accessories

MagSpring® Flange MF01-20/H23 Part-No 0250-2306

Installation Instructions:

1. Install mounting flange with two M4 mounting screws. Do not tighten at this time.
2. Position *MagSpring*® in flange and tighten clamping screw - Max torque: 200 Ncm (1.475 ft lbs.) Over tightening may damage the *MagSpring*.
3. Tighten mounting screws.

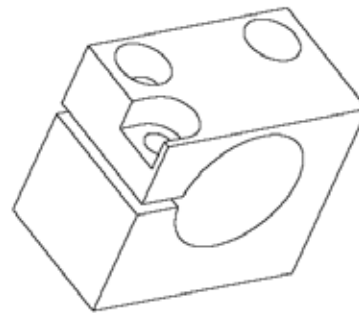
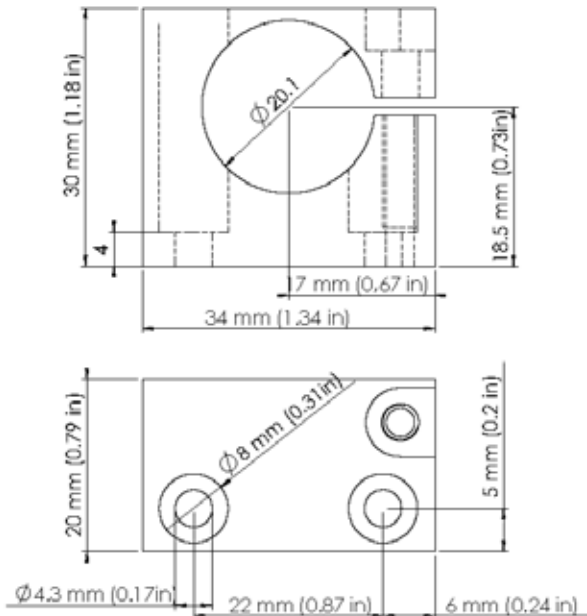

Material: Aluminium (AlMgSi)
 Black anodized
 Weight: ca 30 g (0.066 lb)
 Clamping screw: M4x16 screw ISO 4762 (1)
 Mounting screws: M4x10 screw ISO 4762 with rectangular nuts (for H-Guide) (2)
 Spring washer: M4 (Din 128 A) (3)

Part-No: 0250-2306 MF01-20/H23

MagSpring® Adapter MA01-20/H23 Part-No 0250-0116

Adapter between *MagSpring*® MS01-20 and H-Guide H01-23x..

Material: Aluminium (AlMgSi)
 Black anodized
 Weight: ca 18 g (0.034 lb)
 Clamping screw: M3x18 screw ISO 4762 (1)
 Mounting screws: M5x14 screw ISO 4762 (1)
 Disc Spring washer: DIN 2093A 10/5,2/0,5 (1)

Part-No: 0250-0116 MA01-20/H23

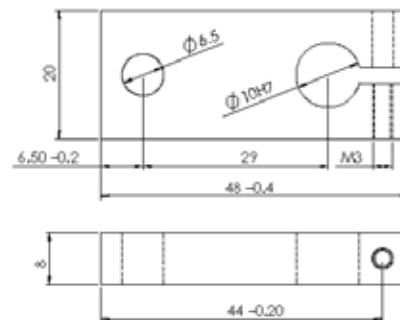

Assembling MagSpring®



MagSpring® Flange MF01-37/H37 Part-No 0250-2307

Installation Instructions:

1. Install mounting flange with two M4 mounting screws. Do not tighten at this time.
2. Position MagSpring® in flange and tighten clamping screw - Max torque: 200 Ncm (1.475 ft lbs.) Over tightening may damage the MagSpring®. Align MagSpring® with H-Guide rods
3. Tighten mounting Flange screws (Note: with M01-37 MagSprings® it will be necessary to remove MagSpring® from the mounting bracket in order to tighten mounting Flange screws.

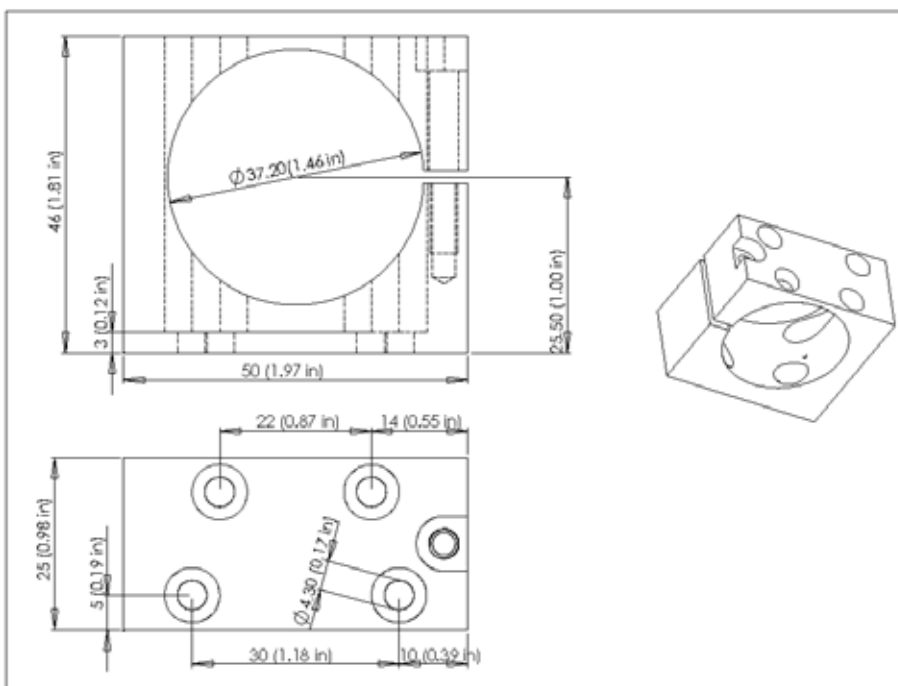

all dimensions in mm / () denotes inch

- Material:** Aluminium (AlMgSi)
Black anodized
- Weight:** ca 70 g (0.15 lb)
- Clamping screw:** M4x25 screw ISO 4762 (1)
- Mounting screws:** M4x10 screw ISO 4762 (with rectangular nut for H-Guide) (2)
- Spring washer:** M4 (Din 128 A) (3)
- Part-No:** 0250-2307 MF01-37/H37

MagSpring® Adapter MA01-37/H37 Part-No 0250-0117

Adapter between MagSpring®MS01-37 and H-Guide H01-37x..



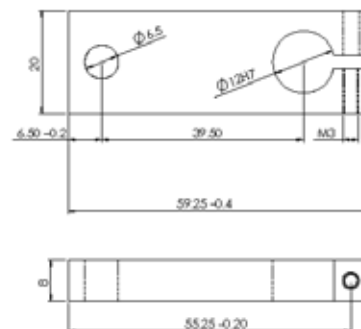







- Material:** Aluminium (AlMgSi)
Black anodized
- Weight:** ca 18 g (0.034 lb)
- Clamping screw:** M3x18 screw ISO 4762 (1)
- Mounting screws:** M5x14 screw ISO 4762 (1)
- Disc Spring washer:** DIN 2093A 10/5,2/0,5 (1)
- Part-No:** 0250-0117 MA01-37/H37



Assembling *MagSpring*[®]



Mounting of the magnetic spring *MagSpring*[®] to H-Guide

<p>1a</p>	 <p>Parts: H-Guide Assembly, <i>MagSpring</i>[®], Mounting Flange, Coupling, Misc. Hardware</p>	<p>1b</p>	 <p>Pre-assemble mounting screws and rectangular nuts on to mounting Flange.</p>
<p>1c</p>	 <p>Place Flange on H-Guide with rectangular nuts in T-slot of H-Guide.</p>	<p>1d</p>	 <p>Tighten mounting Flange screws only enough to make mounting Flange 'snug' on H-Guide</p>
<p>1e</p>	 <p>Insert <i>MagSpring</i>[™] into mounting Flange and lightly tighten clamping screw</p>	<p>1f</p>	 <p>Align <i>MagSpring</i>[®] with H-Guide rods. Note: Axis of <i>MagSpring</i>[®] must be absolutely parallel to rods of H-Guide</p>
<p>1g</p>	 <p>Tighten mounting Flange screws (Note: with M01-37 <i>MagSprings</i>[®] it will be necessary to remove <i>MagSpring</i>[®] from the mounting bracket in order to tighten mounting Flange screws – replace <i>MagSpring</i>[®])</p>	<p>1h</p>	 <p>Move <i>MagSpring</i>[®] to desired position and tighten clamping screw (200 Ncm (1.41 ft.lbs))</p>
<p>1i</p>	 <p>Attach Adapter to end of <i>MagSpring</i>[®] and to H-Guide rod. Use Disc Spring washer between <i>MagSpring</i>[®] Slider and Adapter 2093A 10/5,2/0,5 (1)</p>	<p>1j</p>	 <p>Check Alignment – all parts must move freely. If tight spots or resistance to free movement is noted, realign as necessary</p>

Assembling MagSpring®



Declaration of Conformity CE-Marking

Manufacturer: NTI AG
 Haerdlistrasse 15
 8957 Spreitenbach
 Switzerland
 Tel.: +41 (0) 56 419 91 91
 Fax: +41 (0) 56 419 91 92

Products: *MagSpring*® Magnetic Springs

Type	Art.-No.	Type	Art.-No.
ML01-12x130/80-10	0250-2300	MS01-20x60	0250-2200
ML01-12x130/80-15	0250-2308	MS01-20x140	0250-2201
ML01-12x130/80-20	0250-2301	MS01-20x220	0250-2202
		MS01-20x300	0250-2207
ML01-12x210/160-10	0250-2302		
ML01-12x210/160-15	0250-2309	MS01-37x80	0250-2203
ML01-12x210/160-20	0250-2303	MS01-37x155	0250-2204
		MS01-37x230	0250-2205
ML01-12x290/240-10	0250-2304	MS01-37x305	0250-2206
ML01-12x290/240-15	0250-2310		
ML01-12x290/240-20	0250-2305		
ML01-12x370/240-10	0250-2311		
ML01-12x370/240-15	0250-2312		
ML01-12x370/240-20	0250-2313		
ML01-12x335/240-20	0250-2320		
ML01-12x350/240-20	0250-2321		

The product must be mounted and used in strict accordance with the installation instruction contained within the User's Manual, a copy of which may be obtained from NTI AG.

I declare that as the authorized representative, the above information in relation to the supply/manufacture of this product is in conformity with the stated standards and other related documents in compliance with the protection requirements of the EMC Directive (89/336/EEC) and is marked in accordance with the CE Marking Directive (93/68/EEC).

Company
 NTI AG

Spreitenbach, Dez, 2005



Dr.-Ing. Ronald Rohner / CEO NTI AG

Assembling MagSpring®**Contact Addresses****NTI AG**

Haerdlistrasse 15
CH-8957 Spreitenbach
Switzerland

Tel.: +41 (0)56-419 91 91
Fax: +41 (0)56-419 91 92
E-Mail: office@linmot.com
Web: www.linmot.com

LinMot Inc.
N5750 Townline Road
Elkhorn
WI 53121
USA

Sales: 877-546-3270
262-743-2555
Tech. Service: 877-804-0718
262-743-1284
Fax: 800-463-8708
262-723-6688
E-Mail: sales@linmot-usa.com
Web: www.linmot-usa.com

NTI AG (as a manufacturer of LinMot and MagSpring products) is not responsible for any damages caused by improper use, application, or handling of NTI AG manufactured or supplied materials and is not responsible for any consequential damages of any sort relating to the use of LinMot or MagSpring products.

NTI AG's warranty is limited to repair or replacement as stated in our standard warranty policy as described in our "terms and conditions" previously supplied to the purchaser of our equipment (please request copy of same if not otherwise available). Product warranties are void if products are used with stators, sliders, or controllers not manufactured by NTI AG unless such use was specifically approved by NTI AG.

A copy of this notice must be attached to each motor and/or machine that the purchaser provides to others.

LinMot® and MagSpring® are registered trademarks of NTI AG

Specification of products are subject to change without notification

Enclosure_MagSpring_Assembling_V1.2_e040317.doc